



POTENTE 320W - 1440W

Emergency Lighting Power Supply - Pure Sine Wave

Project Name: _____ Model Number: _____
 Prepared By: _____ Date: _____

FEATURES AND BENEFITS

- 120 or 347V
- Momentary push button test switch
- LCD Display panel
- Normally ON and OFF
- Separate battery compartment
- Steel construction
- Overload protectors Fuse with max load of 175A
- 1,000W: board protection up to 1,100W
- 1,440W: board protection up to 1,500W
- CSA 22.2 No. 141-15 Performance Certified

The **POTENTE** pure sine wave inverter represents a unique approach to power failure lighting applications. Pure sine wave inverters are ideal, as opposed to square or modified wave inverters, which will break down electronic ballasts and LED drivers prematurely. BeLuce's pure sine wave inverter was designed to run up to 1,440W for 30 minutes on normally ON and OFF LED, CFL, fluorescent or incandescent lighting fixtures.

PURE SINE WAVE

True sine wave power is required to ensure there is no interruption in delivering emergency power. The pure sine wave system is compatible with all power supplies, LED drivers and lighting ballasts.

DIMENSIONS

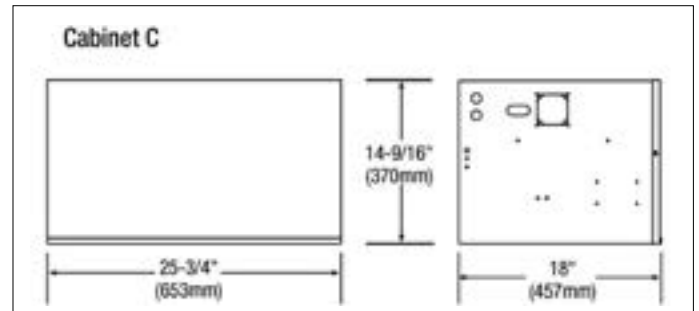
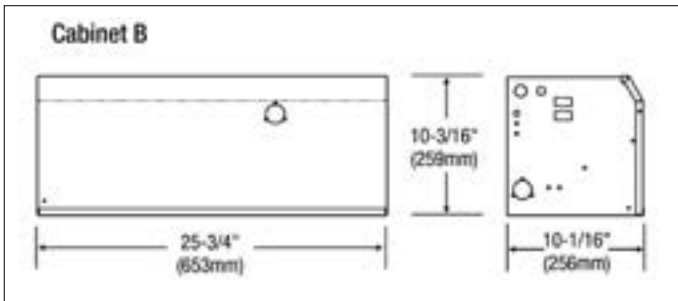

ORDERING GUIDE

PTN - - -

SERIES	WATTAGE	VOLTAGE	OPTIONS
PTN	^{1,3} 320W	A = 120V	AT (Auto Test - self-diagnostic -non audible)
	^{1,3} 500W	C = 347V	
	^{1,2} 1000W		
	^{1,2} 1440W		

NOTE¹: May accept load to 80% capacity when load feature power factor of 0.9 or more; **NOTE²:** May accept the surge peak lighting load of 3000W for 0.5 seconds for 1000W and above; **NOTE³:** May accept the surge peak lighting load of 1200W for 0.5 seconds for 320W and 500W

MODEL RATING GUIDE

MODEL	30 MIN	60 MIN	90 MIN	120 MIN	180 MIN
PTN-320W	320W	180W	125W	110W	75W
PTN-500W	500W	280W	195W	175W	125W
PTN-1000W	1000W	565W	395W	350W	250W
PTN-1440W	1440W	850W	595W	525W	375W

SHELF DIMENSIONS

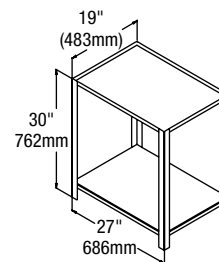

ACCESSORY

PART NUMBER	DESCRIPTION
50001200	PTN WHITE FREE STANDING INVERT SHELF

NOTE: Only compatible with 1000W & 1440W



POTENTE 320W - 1440W

Emergency Lighting Power Supply - Pure Sine Wave

AC EMERGENCY LIGHTING

The **POTENTE** mini-inverter is designed to provide power output based on the input voltage, either 120V AC or 347V AC. The **POTENTE** features a momentary push-button test switch, diagnostic LEDs for AC ON and CHARGE indication, a fully automatic current-limited charger, line-latched low voltage protection, and brownout and short circuit protection. The device includes terminal block connectors for output load, standard dimming override control, an auto transfer switch for normally-on lighting circuits, and maintenance-free sealed lead-acid battery(s).

OPERATION

Normally OFF

By combining a battery unit and offline inverter with superior 120V or 347V lighting performance for all types of lighting fixtures, the **POTENTE** provides exceptional power failure lighting. The typically configured battery unit is paired with an offline, internally mounted, pure-sine wave inverter. When AC power is present there is no output and the connected fixtures are off, when the AC power fails, the unit outputs 120 VAC or 347 VAC to the connected lighting fixtures at 100% brightness.

Normally ON

This feature is easily activated by connecting a normally-ON lighting circuit to the unit. When AC power is present there is output and the connected lighting fixtures are on. When the AC power fails, the output is then transferred to the power failure mode of the inverter and the connected lighting fixtures stay on.

CONSTRUCTION

- Cabinet B: 18 Gauge steel construction
- Cabinet C: 16 Gauge steel construction
- Universal spider knockout pattern and keyhole mounting slots stamped into back of cabinet
- Multiple conduit entry knockouts
- Air intake and exhaust fan placed on the sides for 1,000 W and more
- White powder coat finish standard
- Separate battery compartment

SAFETY

GSA certified to C22.2 #141-15

ELECTRICAL

- 120V AC input / 120V AC output or 347V AC input / 347V AC output
- Momentary push button test switch
- Diagnostic/pilot LEDs for AC ON and CHARGE
- Fully automatic, current limited charger
- Line latched, low voltage protection
- Brownout and short circuit protection
- Terminal block connectors for output load
- Dimming override control is standard
- Auto transfer switch for normally-on lighting circuit
- Maintenance free, sealed lead acid battery(s)

Overload protectors:

- **1,000 W** : Fuse allowing max load of 175 A and board protector with protection up to 1,100 W
- **1,440 W** : Fuse allowing max load of 175 A and board protector with protection up to 1,500 W
- **Optional automatic-testing, self-diagnostic charger:**
- Continuously monitors the unit's status
- Automatically performs battery load testing and auto-cycling at preset intervals
- Indicates malfunctions or auto-test failures
- May accept load to 80% capacity when load feature power factor of 0.9 or more

WEIGHT

120V

WATTS (W)	CABINET	WITHOUT BATTERY(S) (LBS)	WITH BATTERY(S) (LBS)
320W	Cabinet B	29.2	53
500W	Cabinet B	29.1	71
1000W	Cabinet C	61.3	145
1440W	Cabinet C	63.4	189

347V

WATTS (W)	CABINET	WITHOUT BATTERY(S) (LBS)	WITH BATTERY(S) (LBS)
320W	Cabinet B	41.2	65
500W	Cabinet B	42.1	84
1000W	Cabinet C	98.3	182
1440W	Cabinet C	100.4	226