



PROTEGGA RM (PTG-RM)

INSTRUCTIONS

IMPORTANT SAFEGUARDS

When using electrical equipment, basic safety precautions should always be followed including the following:

1. **READ AND FOLLOW ALL SAFETY INSTRUCTIONS**
2. Disconnect power before performing work on electrical equipment.
3. Use caution when servicing batteries.
4. Equipment should be mounted in locations and at heights where unauthorized personnel will not readily subject it to tampering.
5. The use of accessory equipment not recommended by BeLuce Canada Inc., may cause an unsafe condition, and will void the unit's warranty.
6. Do not use this equipment for other than its intended purpose.
7. Servicing of this equipment should be performed by qualified service personnel.
8. **SAVE THESE INSTRUCTIONS!**

INSTALLATION

SINGLE FACE:

1. Remove all screws on the front cover / faceplate and then remove the cover.
2. Mount the exit securely in place using the appropriate end ceiling or wall mounting diagram.
3. Use a rated watertight conduit hub(s) to connect the conduit to the enclosure.
4. Pass power wires through the connector.
5. Connect supply per diagram provided. Insulate unused wire!
CAUTION! Failure to insulate unused wire may result in a shock hazard or unsafe condition as well as equipment failure.
6. Route wires and secure them in place.
7. Replace the cover and tighten the screws.
8. Turn on the AC voltage supply.

DOUBLE FACE:

1. Double face exits are shipped with a weatherproof ceiling or end mount canopy already installed (in either the top or end configuration), as specified when ordered.
2. Loosen the screws on the front cover / faceplate and then remove the faceplate. The other faceplate is attached from the inside with screws recessed behind the front ones.
3. Unscrew the remaining metal screws holding the rear faceplate to the housing.
4. Route wires and secure them in place.
5. Connect supply per diagram provided. Insulate unused wire!
CAUTION! Failure to insulate unused wire may result in a shock hazard or unsafe condition as well as equipment failure.
6. Secure the weatherproof canopy (and connected exit frame) in place – supplied mounting holes fit most standard electrical boxes. Make sure that the canopy gasket is aligned in place between the canopy and the surface you are mounting to.
7. Re-install the exit faceplates starting with the rear faceplate by following steps 2 and 3 in reverse.
8. Turn on the AC line voltage supply and the exit should light up.

SELF-POWERED:

1. For models PTG-SP, plug the battery into the circuit board per (Figure 3) self-powered sign.

Figure 1

Ceiling/End Mount



Figure 2

Wall Mount

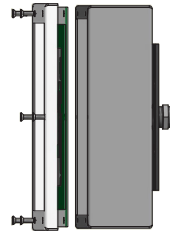
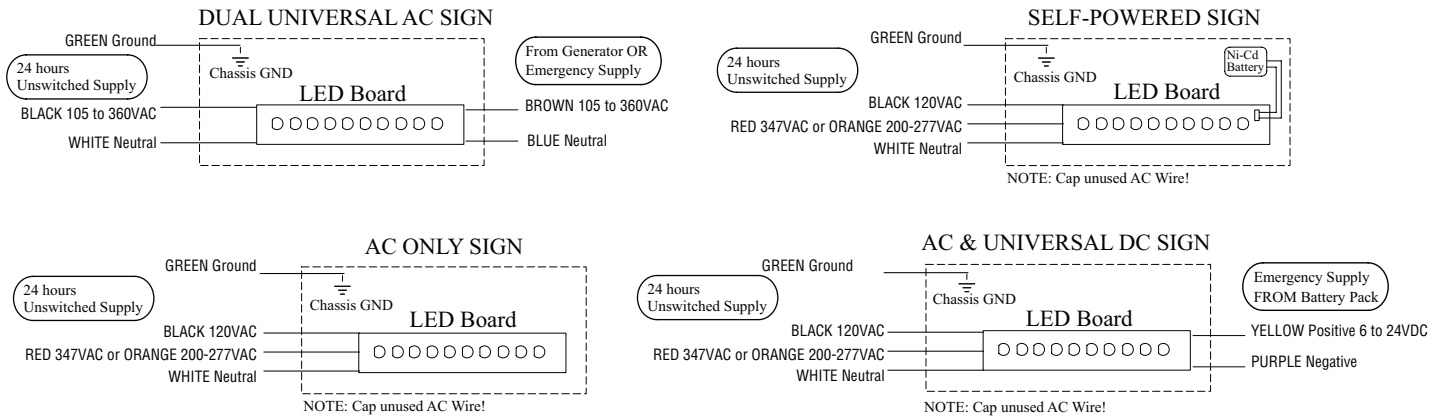

Figure 3



MAINTENANCE

1. The equipment is to be repaired whenever the equipment fails to operate as intended during the duration test. Written records of test results and any repairs made must be maintained. BeLuce Canada Inc. strongly recommends compliance with all Code requirements.
2. The lamps listed herein when used according to the instructions with this unit are in accordance with the requirements of CSA Standard C22.2, No. 141 – Unit Equipment for Emergency Lighting.
3. Clean exit face(s) on a regular basis.

NOTE: The servicing of any parts should be performed by qualified service personnel only. The use of replacement parts not furnished by BeLuce Canada Inc., may cause equipment failure and will void the warranty.

TROUBLESHOOTING

LEDS DO NOT COME ON AT ALL

1. Check AC supply be sure unit has 24 hour AC supply (unswitched).
The AC supply must be at least 80% of nominal (96V on a 120V line) for equipment to function normally. At lower voltages the LED lamps will begin to glow dimly until the source voltage drops below the full “turn on” point.
NOTE: This condition may also be caused by incorrectly connecting an AC Volt supply line to the lead.
2. Check all AC connections
3. AC supply is OK, replace LED Board Assembly.

SAVE THESE INSTRUCTIONS