



VERDE RM COMBO (VE-RM)

INSTRUCTIONS

IMPORTANT SAFEGUARDS

When using electrical equipment, basic safety precautions should always be followed including the following:

1. **READ AND FOLLOW ALL SAFETY INSTRUCTIONS**
2. Disconnect power before performing work on electrical equipment.
3. Do not use outdoors.
4. Use caution when servicing batteries.
5. Equipment should be mounted in locations and at heights where unauthorized personnel will not readily subject it to tampering.
6. The use of accessory equipment not recommended by BeLuce Canada Inc., may cause an unsafe condition, and will void the unit's warranty.
7. Do not use this equipment for other than its intended purpose.
8. Servicing of this equipment should be performed by qualified service personnel.
9. **SAVE THESE INSTRUCTIONS!**

INSTALLATION

WALL MOUNT - SINGLE FACE:

1. Extend unswitched 24 hour AC supply of rated voltage to junction box or appropriate wiring (supplied by others). Leave at least eight (8) inches of slack wire. The circuit should not be energized at this time.
2. Install one (1) plug into the frame to close canopy holes, push to snap into place.
3. Knock out the appropriate mounting pattern and/or wire pass-thru hole on the back plate to fit the junction box or wiring connector being used (supplied by others).
4. Bring the wires through the back of the sign and mount the sign securely in place. Screw directly to the junction box if possible.
5. Connect AC supply per diagram provided (Figure 6). **Insulate unused wire!**
CAUTION! - Failure to insulate unused wire may result in a shock hazard or unsafe condition as well as equipment failure.
6. Route wires and secure them in place.
7. Plug battery connector(s) into charger board (Figure 5).
8. Position the pictogram between the posts on the inside of the faceplate and secure with 6 push nuts. (Figure 3)
9. Install faceplate and snap into frame.
10. Turn on the AC voltage supply.
11. Remove lens. Position lamps by manually rotating to achieve best light distribution, reinstall lens.

CEILING - SINGLE OR DOUBLE FACE:

1. Extend unswitched 24 hour AC supply of rated voltage to junction box or appropriate wiring (supplied by others). Leave at least eight (8) inches of slack wire. The circuit should not be energized at this time.
2. Remove back plate from frame (unsnap). For double face only.
3. Feed wires through frame and through canopy (Figure 4).
4. Install canopy into frame, insert and slide sideways to engage (Figure 4).
5. Connect AC supply per diagram provided (Figure 6). **Insulate unused wire!**
CAUTION! - Failure to insulate unused wire may result in a shock hazard or unsafe condition as well as equipment failure.
6. Route wires and secure them in place.
7. Secure canopy to junction box.
8. Plug battery connector(s) into charger board (Figure 5).
9. Position the pictogram between the posts on the inside of the faceplate and secure with 6 push nuts. (Figure 3)
10. Install faceplate, snap into frame.
11. Remove lens. Position lamps by manually rotating to achieve best light distribution, reinstall lens.

Figure 1

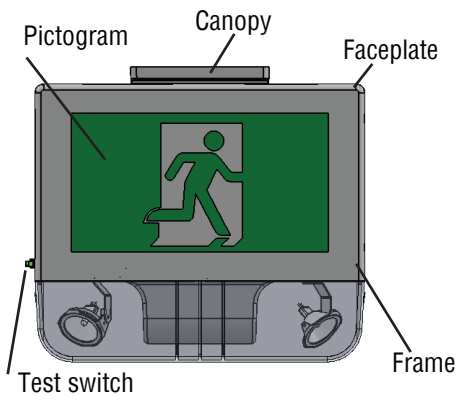

Figure 2

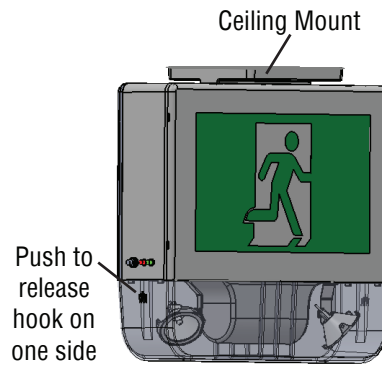

Figure 3

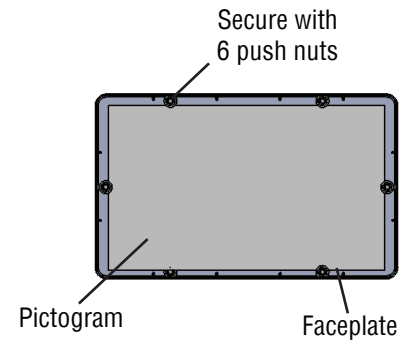

Figure 4

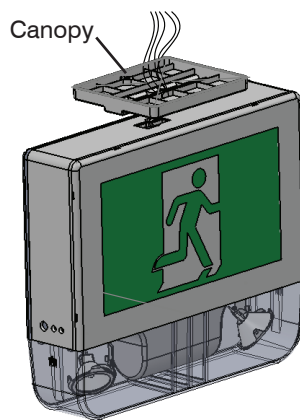

Figure 5

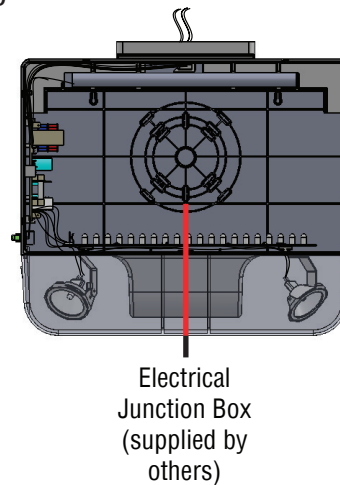
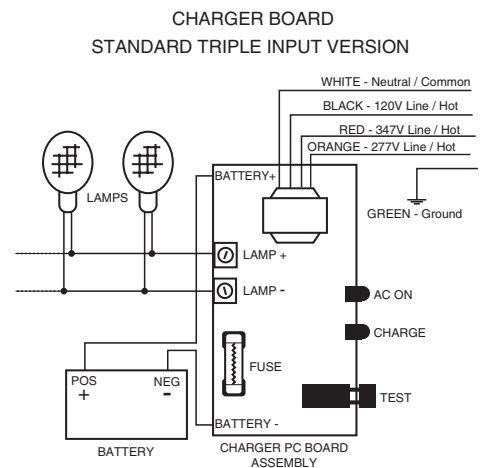

Figure 6



MAINTENANCE

1. Code requires that the equipment be tested every 30 days for 30 seconds, and that written records be maintained. Further, the equipment is to be tested once a year for the duration required as per Code. The equipment is to be repaired whenever the equipment fails to operate as intended during the duration test. Written records of test results and any repairs made must be maintained. BeLuce Canada Inc. strongly recommends compliance with all Code requirements.

2. Clean sign face(s) on a regular basis.

NOTE: The servicing of any parts should be performed by qualified service personnel only. The use of replacement parts not furnished by BeLuce Canada Inc., may cause equipment failure and will void the warranty.

TROUBLESHOOTING

SIGN DOES NOT COME ON AT ALL

1. Check AC supply and all AC connections - be sure exit has 24 hour AC supply (unswitched).
2. Check supply voltage and AC connections. The AC supply must be at least 80% of nominal (96V on a 120V line) for equipment to function normally. At lower voltages the LEDs will begin to glow dimly until the source voltage drops below the full "turn-on" point.

NOTE: This condition may also be caused by incorrectly connecting a 120 Volt supply line to the 277-Volt capacitor assembly lead.

3. AC supply is OK; replace LED circuit board assembly.

TROUBLESHOOTING

IF THE EMERGENCY LIGHTING FIXTURE IS EXPERIENCING ONE OF THE FOLLOWING PROBLEMS:

- The LED indicator is off or displaying the wrong status.
- The LED strip is on during AC power, but there is no emergency backup function.
- The LED strip is on, but the battery is not charging (battery voltage is low).

PERFORM A HARD RESET ON THE BATTERY AND CHARGER BOARD Steps to Perform a Hard Reset:

1. **Disconnect AC Power:** Turn off the AC power supply to the emergency lighting fixture.
2. **Unplug the Battery:** Safely disconnect the battery pack from the charger board.
3. **Wait for 10 Seconds:** Allow the system to completely discharge by waiting a minimum of 10 seconds.
4. **Reconnect Power:** Plug the battery pack back into the charger board.
5. **Restore the AC power** to the fixture.
6. **Verify the Reset:**
 - I. Check that the LED indicator is functioning correctly.
 - II. Ensure that the battery is charging and the emergency backup function is operational.

NOTE: If the issue persists after performing the hard reset, further inspection of the fixture or professional assistance may be required.

SAVE THESE INSTRUCTIONS